



Boat Lift Manual

Important information
for the use, safety and
maintenance of your
boat lift



Customer Service
870-480-2820

Welcome

We are pleased to welcome you to the growing number of boaters who own a Bottom's Up boat lift.

This manual will introduce you to the features and operation of

your new lift. Please read it carefully. The information it contains can contribute greatly to the life of your lift.



If you have any questions concerning the operation or maintenance of your lift, please contact us.

Bottoms Up Boat Lift Systems, LLC is proud to be family owned and operated. Quality products, advanced design, expert craftsmanship, and prompt customer services are what we strive to provide for all members of our Bottoms Up Family. We are ecstatic to give you “The Ultimate Solution” for protecting your investment.

We're especially thankful to you, our valued customer, and pledge to continue providing you with superior service.

Basic Lift Operation

Raise:

1. From the **HOLD** position, turn handle(s) to **RAISE/LOWER** position(s).
2. Turn blower switch **ON**
3. When raised, turn the blower switch **OFF** and turn handle(s) to **HOLD** position



To Lower:

1. From the HOLD position, turn all handle(s) to **LOWER** position
2. When the boat is floating free, turn handle(s) back to the **HOLD** position.

Recommendation:

We suggest securing your boat to the dock with a rope as a precaution if the lift is lowered in your absence.

CAUTION: Do not leave lift in the down position for extended periods of time. In the down position, the lift can become a burden to the dock resulting in potential damage to the dock or the lift.

Safety

Know the maximum capacity of your lift. (Length and Weight)

It is important not to exceed the maximum lifting capacity of your boat lift. Overloading it could cause mechanical failure and serious personal injury. Be especially cautious of lifts without canopies because the boat's weight could greatly increase during a rainstorm and exceed the lift's capacity. If your boat is too long for your boat lift's recommended maximum length, your boat could tip forward or backward. This too can cause mechanical failure and serious personal injury.



Never board a boat while it is raised on the lift.

Before boarding, always lower the lift so the boat is almost floating free, but still stabilized by the bunks.

Do not let children play on or around the lift. Children should only be allowed near the lift with adult supervision. "Pinch points" are a hazard even when the lift is not being operated; waves alone can create this hazard.

Recommended Maintenance

Your Bottom's Up lift requires very little maintenance. We recommend the steps below every quarter.

Additional inspections should follow a severe windstorm, substantial fluctuation in the water level, or heavy wave action.

Use caution during maintenance and repairs.

During maintenance or repairs, remove the boat from the lift and be sure the lift is level. Set the blower in the "hold" position.

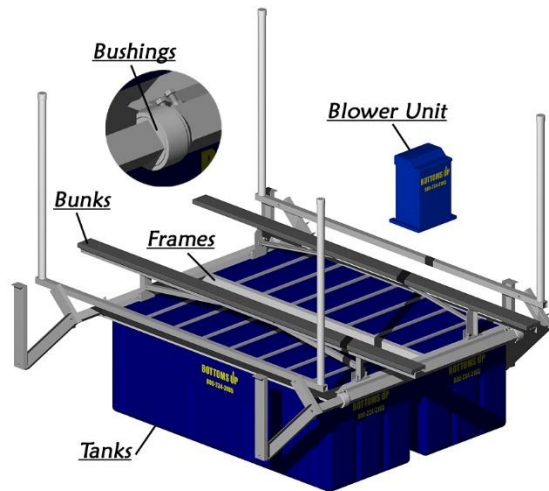

Recommended Steps

1. Check all nuts and bolts for tightness and excessive deterioration. Even when plated nuts and bolts are used, friction and physical elements can still degrade the bolts over time.
2. Inspect all UHMW washers and bushings to ensure none are missing and check them for cracks, breakage, and general wear. (Call us to schedule a service call if you would like our trained technicians to come inspect your lift or replace any wearing parts.)
3. Clean all visible parts with a biodegradable soap and water mixture. During cleaning, inspect hoses, PVC fittings, and clamps for wear, holes, or other damage.

Bottoms Up Boat Lift Systems has lifts that have been on area lakes that have been in operation for upwards of 30 years. The proper maintenance of your lift is a necessity to ensure its longevity and reliability.

If at any time you have questions or concerns, we are here for you!

Thank you for your
purchase of a Bottoms
Up lift. We are
overjoyed to welcome you
to the Bottoms Up
Family!



Warranty

Bottoms Up Boat Lift Systems

53519 W 101st St S
Drumright, Oklahoma 74030

Phone: 870-480-2820 or 800-234-3165
Email: info@bottomsuplifts.com

Blower Unit – 2 Years Manufactured Parts – 5 Years Tanks – 5 Years

It is the customer's responsibility to provide general maintenance. The recommended maintenance sheet is included in this document.

Bottoms Up Boat Lifts are warranted to be free from defects in materials and workmanship for the duration listed above to original consumer. This warranty does not include damage to the product resulting from accident, storm damage, misuse, neglect, alteration, modification, tampering, or failure to follow instructions supplied with the product. It is the customer's responsibility to provide accurate weight of boat, fuel, supplies and equipment to determine proper lift requirements.

This warranty is void if the product is installed, relocated, serviced, or otherwise altered by someone other than our assigned service technicians.

If you deem the product or any part thereof to be defective within the warranty period, notify the manufacturer within ten (10) days of discovering the problem by calling the phone number or emailing us at the contact information listed above. If upon the manufacturer's inspection a defect is found, the manufacturer will, at their option, repair or replace the defective part. If during the inspection, an issue is found that is not covered by warranty, a service call will be charged to the customer. Please note labor, installation, transportation, and/or incidental costs are not covered under warranty.

This warranty is to repair or replace, at the manufacturer's option, and is the only warranty associated with this product whether expressed or implied and the manufacturer's liability is expressly limited to repair or replacement of defective components.

This warranty is valid only in the United States and for products used in fresh water.

You must retain the original invoice as proof that you are the original purchaser and include a copy with correspondence.

This warranty gives you legal rights, and you may also have other rights, which vary from state to state.

The above expressed warranty is the only warranty applicable to the product and there is no implied warranty of merchantability or implied warranty of fitness for a particular purpose.

